



UD TRUCKS

Quester

GWE420

E30 & E31



www.udtrucks.co.za



www.facebook.com/udtrucks



@udtruckssa



info.support@udtrucks.co.za

VEHICLE	E30	E31
Model	GWE420	GWE420
Manufacturers Code	GWE64T11MS	GWE64T11MS
Model Description	6x4 Truck Tractor	6x4 Truck Tractor
MASS		
Tare – total (T) * kg	8 710	9 120
Tare Frt / Rr kg	4 450/4 260	4 460/4 660
GVM kg	31 000	34 000
V kg	25 700	25 700
GCM kg	60 000	60 000
D/T kg	56 000	56 000
Axle – front GA/GAU kg	8 000	8 000
Axle – front A/AU kg	7 700	7 700
Axle – rear GA/GAU kg	26 000	26 000
Axle – rear A/AU kg	18 000	18 000
* Tools included in tare	Yes	Yes
* Spare wheel included in tare	Yes	Yes
* Fifth wheel included in tare	Yes	Yes
PERFORMANCE		
Gradeability at V %	113.3	128.6
Gradeability at D/T %	35.7	37.9
Max. geared road speed km/h	115	109
MAJOR DIMENSIONS		
Overall length mm	7 055	7 055
Overall width mm	2 500	2 500
Wheelbase mm	4 085	4 085
CA – cab to bogie/rear axle mm	3 295	3 295
Turning radius (curb to curb) mm	7 900	7 900
ENGINE		
Model	GH11E	GH11E
Capacity cm ³	10 837	10 837
Layout	In line six cylinder	In line six cylinder
Type	Turbo Intercooled (Unit Injectors)	Turbo Intercooled (Unit Injectors)
Power at r/min kW	315 @ 1 900	315 @ 1 900
Torque at r/min Nm	2 000 @ 1 100 – 1 400	2 000 @ 1 100 – 1 400
Emissions standard	EUR III	EUR III
TRANSMISSION		
Model	STO2012	STO2012
Type	Synchro	Synchro
Shift	Manual	Manual
No. of gears forward	12	12
First gear ratio	12.10	12.10
Top gear ratio	0.78	0.78
Transmission PTO	DIN Conn. Pump	DIN Conn. Pump

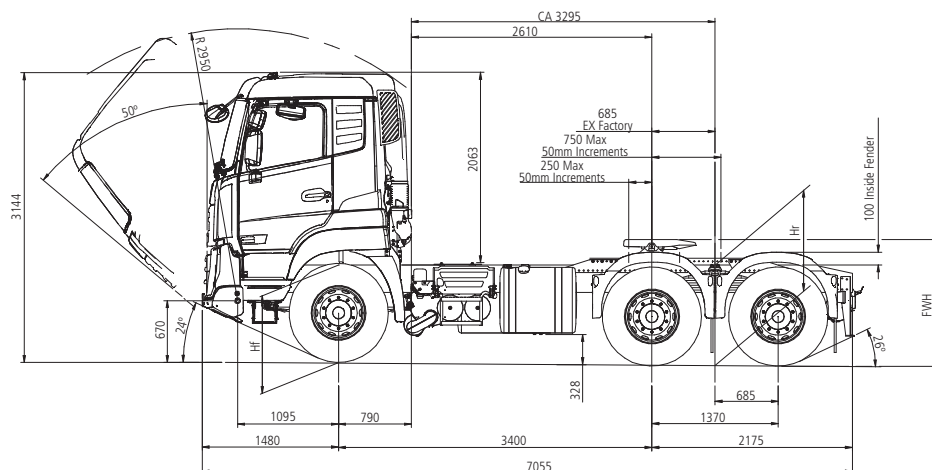
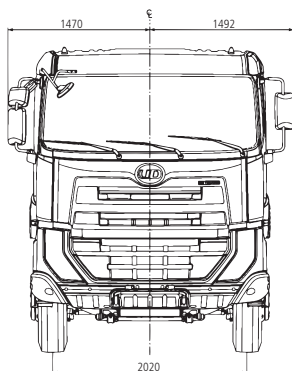

CLUTCH		
Model	Organic	Organic
Type	Dry Single Plate	Dry Single Plate
Diameter mm	430mm	430mm
Operation	Hydraulically Operated	Hydraulically Operated
DRIVE AXLE		
Model	RTS2670	RTH2611
Reduction type	Single Reduction Tandem	Hub Reduction Tandem
Final ratio	4.63	4.87
SUSPENSION		
Front	Parabolic Springs	Parabolic Springs
Rear	Multileaf Spring	Multileaf Spring
Shock absorbers	Front Standard	Front Standard
Stabilisers	Front Standard	Front Standard
STEERING		
Operation	Power Assisted	Power Assisted
BRAKES		
System type	Full Air	Full Air
Front	S-cam Drum Brake	S-cam Drum Brake
Rear	S-cam Drum Brake	S-cam Drum Brake
Electronic brake system	ABS	ABS
Park/emergency system	Wheel Park	Wheel Park
Exhaust brake	Yes	Yes
Engine brake	Yes	Yes
Retarder	No	No
ELECTRICAL & FUEL		
Fuel tank 1 capacity ltrs	405	315
Fuel tank 2 capacity ltrs	315	315
TYRES		
Size – front	315/80R22.5	315/80R22.5
Size – rear	315/80R22.5	315/80R22.5
CAB		
Type	Standard Roof Sleeper Cab	Standard Roof Sleeper Cab
Roof	Standard	Standard
No. of bunks	1	1
No. of seats	2	2
Air conditioning	Standard	Standard
Radio/USB	Standard	Standard
Cruise control	None	None
On-board computer	Multi Display Function	Multi Display Function
Tilt cab	Yes	Yes
Speed limiter	90km/h	90km/h

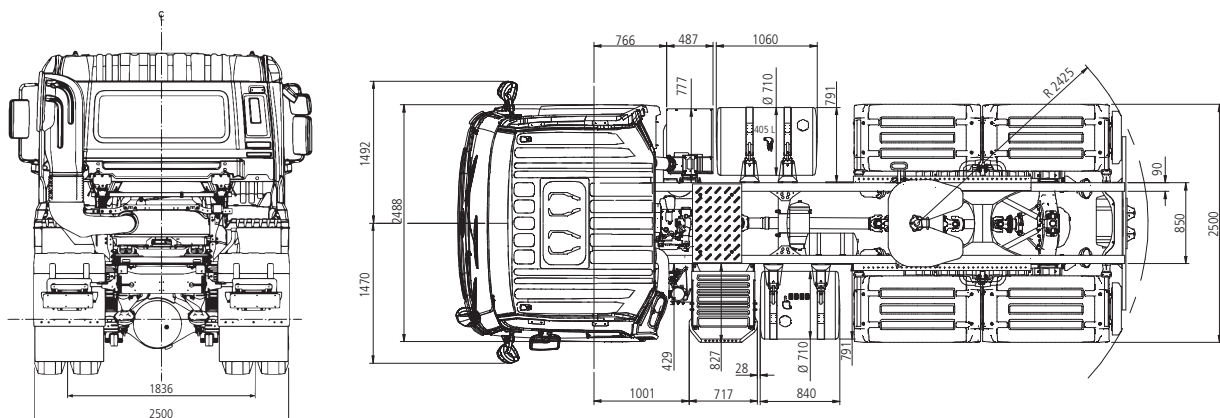

Specifications and options may differ depending on each country due to regulations or special requirements. Dimensions and devices may be changed without prior notice. Please contact your nearest UD Trucks dealer for further details.